

## INSTALLATION INSTRUCTIONS

This garage door has been designed to be as easy as possible to use, service and automate when installed correctly. Please therefore take time to read these instructions fully before beginning any work. **Note:** This door is recommended for fitment to a 70mm × 70mm timber goalpost frame (not supplied). A separate set of instructions should be used if the door has been supplied pre-fitted to a quick-fit steel frame.



**SAFETY FIRST** Please read instructions right through before commencing installation.

**CAUTION** The spring is under tension – follow instructions carefully to avoid any chance of personal injury.

### **IMPORTANT INFORMATION**

- 1 This garage door is intended for domestic use only.
- 2 Garage doors are heavy and may have sharp edges.  
Wear protective gloves. Installation should not be undertaken alone.  
Care must be taken when handling.
- 3 Ensure the door is continuously supported before it is secured and avoid installing in windy conditions.
- 4 Do not attempt to install or adjust this door if you are unsure of any of the instructions below.
- 5 Wear eye protection.

### **WARNING**

When fitting the multi-point latching do not shut the door whilst you are outside the garage until all latches have been correctly set and tested (See instructions 8 & 9) Failure to comply could result in being locked out of the garage and a chargeable service call will be required.

### **IMPORTANT NOTES**

#### **BEFORE COMMENCING WORK:**

- a Remove all wrapping including plastic sleeve from spring. Ensure that your door has been supplied with the correct main fixing pack (fixing pack codes are on the identification label on reverse of door).  
Remove lock pack, fixing pack and the black plastic weather strips from their transit positions on the rear of the door.
- b Before fitting the door, check opening size and squareness of the timber frame. The door is made smaller to give correct clearance within the frame.  
Also check that the existing timber goalpost frame is securely fitted to the surrounding brickwork and is structurally sound.
- c There must be a minimum of 65mm (2½") headroom above lower face of top timber, or lintel. This must reach back into the garage for at least 1300mm (4'3").
- d A 70mm × 70mm (2¾") timber 'goalpost' frame is recommended but the gear only requires a fitting clearance of 45mm per side.
- e All the initial work is carried out from inside the garage so tools and parts should be to hand before door is placed in the opening.
- f Slots are provided in all key components to allow for final adjustment, when door has been installed.

## INSIDE VIEW OF DOOR & GUIDE TO INSTRUCTIONS

### YOU WILL NEED

- 22mm A/F spanner
- 10mm A/F socket/spanner
- Posi screwdriver (Z3 & Z2)
- 4.0mm Drill bit and drill
- Protective gloves
- Eye protection
- Sharp knife
- Tape measure
- Hammer
- Grease
- '3 in 1' type oil
- Engineer's pliers
- Wedges (packing pieces)
- 19mm x 19mm timber weatherbead to fit under the head of the door frame

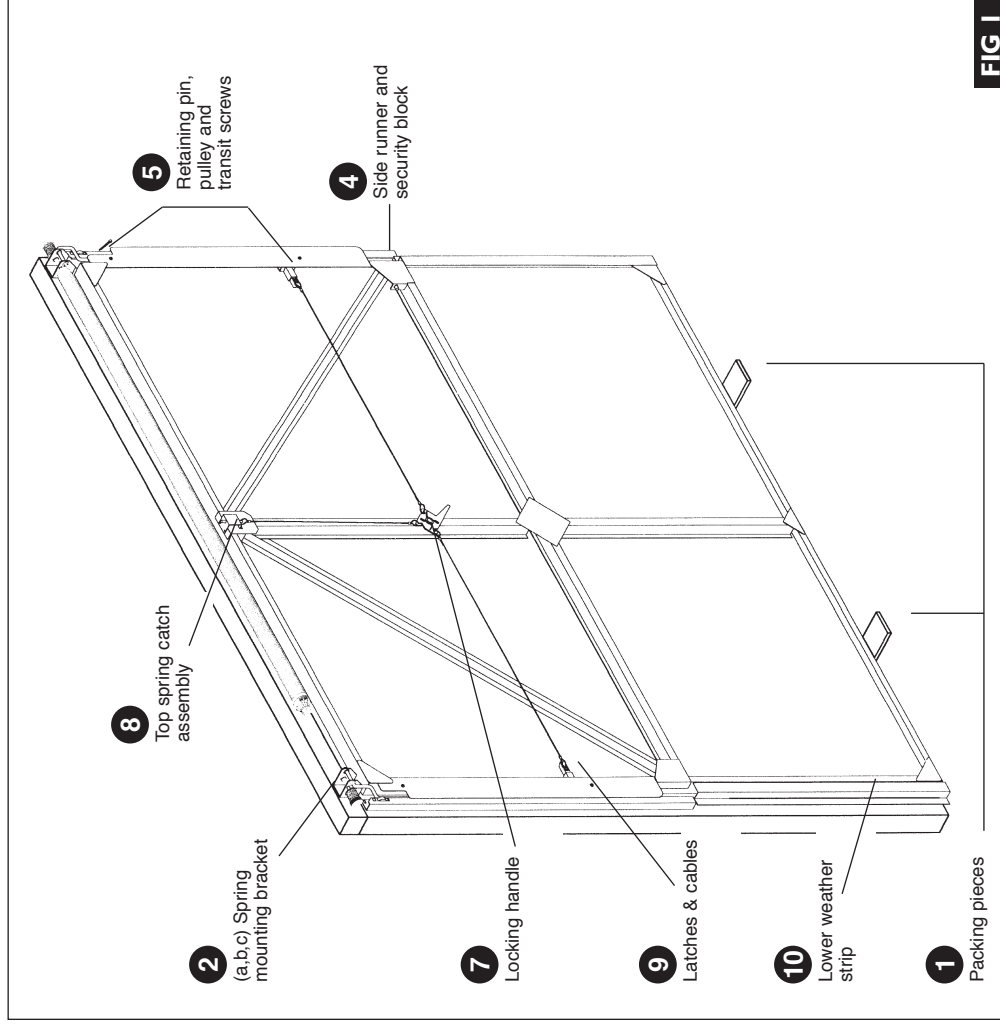

**1** Stand door centrally between side timbers on packers ensuring that the bottom edge of the Spring Mounting Brackets are set level with the underside of the top timber.  
NOTE: For fixing the spring mounting brackets use the special GOLD coloured screws provided. No pilot hole is needed, just drive straight into the timber.

**2 a.** Insert the **gold** coloured screw with M6 washer into the slotted hole at the top of both Spring Mounting Brackets. Do not fully tighten at this stage (see fig. 2).

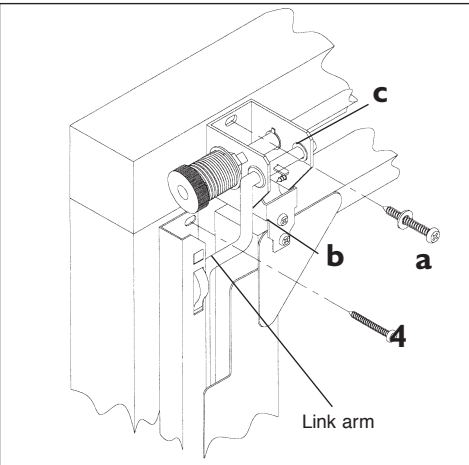
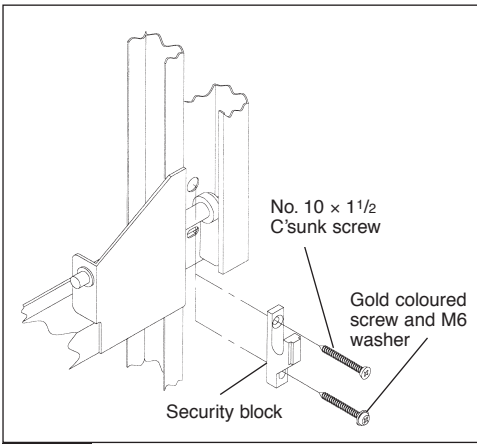

**FIG 2**

- b.** Remove the self tapping screws holding the door to the transit brackets. This allows the top of the door to move forward and the side runners to locate fully against the side timbers.
- c.** Remove remaining screw on the side of the Transit Brackets (see fig. 2) and discard the Transit Brackets.

**3** Re-check that door is positioned centrally between timbers and that both link arms (see fig. 2) are equally set relative to door panel edge (any minor adjustment will be available on the Spring Mounting Bracket top slotted holes) before inserting lower **gold** coloured screw and M6 washer in each side.

**Tighten all four Spring Mounting Bracket screws.**



**FIG 3**

- 4** On the **upper** fixing slot in both runners, pilot drill 4.0 dia. x 25 deep then insert and tighten a No. 12 x 1 1/2" Round Head Posi. screw (see fig. 2).  
Fix Diecast Security Block around Spindle at bottom of runner (ensure block does not foul on nylon wheel) using a **gold** coloured screw and M6 washer into slotted hole. Use adjustment on slot in block to ensure close contact with Spindle. Once final adjustment has been made insert and tighten the No. 10 x 1 1/2" Countersunk Posi screw into top hole on block (see fig 3). Repeat for opposite side.

**5 IMPORTANT** Ensure both cables are within side runners and correctly engaged in grooves of pulleys and into wheel spindle clips.

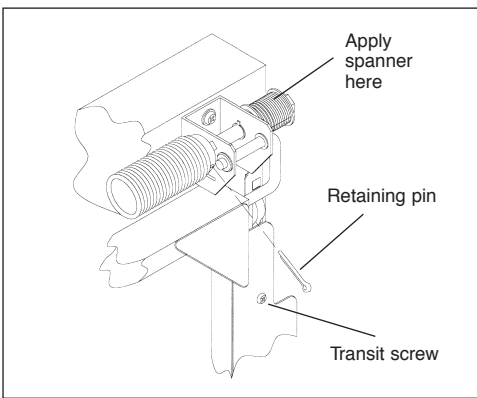
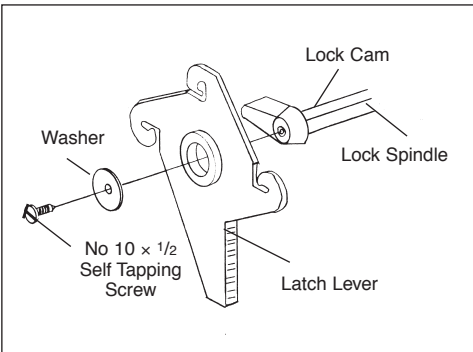

**FIG 4**

Remove the retaining pin from the Spring Anchor Bush with assistance of spanner on pulley (see fig. 4). You now have tension on the door. Take out 2 transit screws and spacer from each upper weather strip. Open/close door through full travel to test runner position. If necessary make final adjustment to runners for correct operation. With door open insert 5 screws per side (No.8 x 1") down each side runner.

**6** At this stage it is necessary to fit the lock. Refer to separate instructions provided with the lock pack for fitting procedure.

**7** From the front of the door, ensure handle is turned fully anti-clockwise. From inside garage place plastic lock cam onto the square lock spindle in orientation shown in fig 5. Fit latch lever over lock cam as shown and fix with self tapping screw and large washer provided.



**FIG 5**

**8** With the door slightly open take top spring catch assembly and engage into formed tag (see fig. 6). Align fixing holes with those in top of door and insert self tapping screws (No. 10 x 1/2") provided. With door closed, remove park pin to release latch pin (see fig 7). Align spring support/catch bracket centrally over latch pin with lower face level with the underside of the head timber (see fig. 7) Insert two No. 12 x 1 1/2" Posi Screws and use sideways adjustments on screw slots to ensure correct alignment.

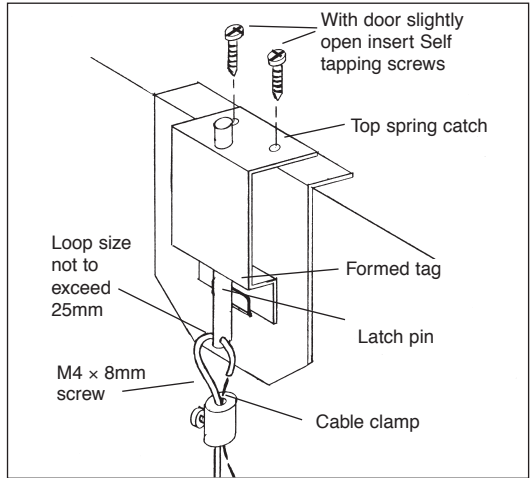

**FIG 6**

Take the shorter cable with single loop from pack and hook looped end onto top hook on latch lever.

Slide cable clamp over free end, route cable through hole in latch pin and return through clamp (see fig. 6). **Note** Loop size not to exceed 25mm. Adjust length of cable to ensure correct catch pin engagement (see fig. 7). Tighten screw in clamp on completion of adjustment.

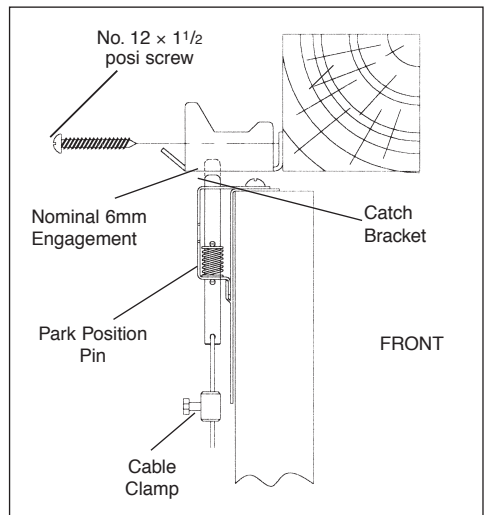

**FIG 7**

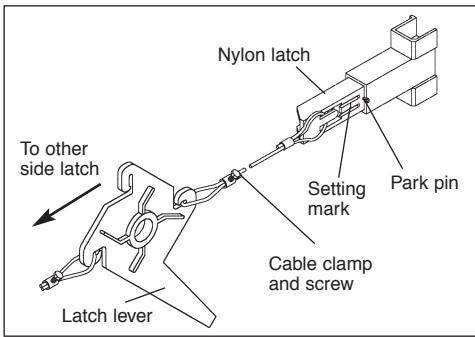

**FIG 8**

- CAUTION** Do not close door from outside until all latches have been checked for correct setting and operation. Failure to follow these instructions carefully may result in a lock out situation and a chargeable service call may result.

Take cable with double loop and attach looped end of cable (without clamp) in centre groove of nylon latch (see fig. 8). Loop the other end of the cable over the closest arm on the internal latch lever. Repeat this operation for both side latches. Remove 'Park pins' to release latches (see fig. 8). The setting mark on the nylon latch (see fig. 8) indicates nominal latch position but adjustment may be necessary to ensure correct latch engagement. This can be done by either looping the cable over a different groove in the latch (see fig. 8) or by loosening the screw on the cable clamp, moving cable slightly and re-tightening.

**IMPORTANT** Test latches for correct operation.

- Side latches should engage behind side

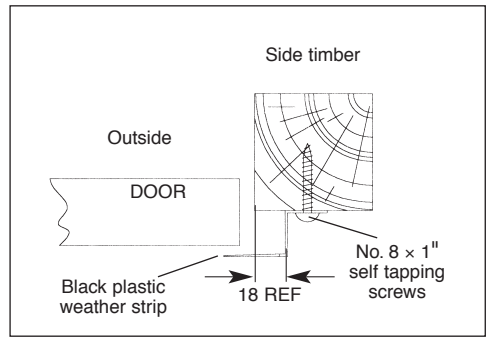

**FIG 9**

runners by approx. 6mm.

- All latches should be fully released when the external lock handle is rotated clockwise.

- Fix black plastic weather strips (LH & RH) to the side timbers using No.8 x 1" screws provided (see fig 9). Position the weather strip so that the shaped end fits around the wheel spindle, between the security block and edge flange of the runner. Any excess length can be cut off from the bottom.

- IMPORTANT** Fix 19mm x 19mm ( $\frac{3}{4}$ " x  $\frac{3}{4}$ " ) wooden weather beading securely to the underside of the head on the outside of the door (see fig.10).

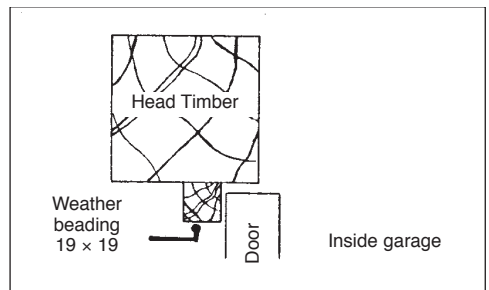

**FIG 10**

## NOTES ON COMPLETION

- On completion of installation lubricate the spring, wheel spindles and all pivot points with a '3 in 1' type lubricant.
- Grease top catch pin to ensure smooth operation. (Do not grease side latches).
- Check that all fasteners are fully tightened.
- Ensure track runners are clean and door operates smoothly through full open/close cycle.
- It is the responsibility of the installer to ensure that the spring tension is correctly set. If the tension requires adjustment, refer to maintenance label on rear of door.
- Do not paint spring or any moving parts.

**DISMANTLING INSTRUCTIONS**

**THESE INSTRUCTIONS MUST BE FOLLOWED CAREFULLY**

**GARAGE DOORS ARE HEAVY AND AWKWARD TO HANDLE. ENSURE ASSISTANCE IS AVAILABLE AND THAT SAFETY GLOVES ARE WORN.**

1. Open door and remove the intermediate screws from the side runners, leaving the top and bottom fixings in place.
2. Wearing safety glasses, close door and grip R/H blue pulley with 22mm A/F spanner and by turning upwards, align holes in spring anchor bush and spring shaft. Insert retaining pin (4mm dia. x 50mm split pin or similar) fully into this hole as shown, then remove the spanner. (See Fig. 4)
3. Insert 4 off No. 10 x 1/2" self tapping transit screws through the top side seal to secure the side runners in place. (See Fig.1)
4. Remove lower rubber weatherstrips. (See Fig.1)
5. Remove 4 screws securing the two spring mounting brackets. (See Fig.2)
6. Using cable ties, or strong cord, or similar, tie the spring assembly securely to the door panel.
7. Remove top catch bracket. (See Fig.7)
8. Prop door in position.
9. Remove top and bottom track fixings including security block.
10. The door can now be carefully removed from the opening. Seek assistance in lifting.

IN THE EVENT OF DIFFICULTY PLEASE CONTACT YOUR LOCAL GARAGE DOOR SPECIALIST  
– SEE YELLOW PAGES FOR DETAILS